

CI/SfB	(31)	Zt4
CAW P10		
Uniclass L675:P91		

## Description

TP450 is a soft and flexible open cell polyurethane foam, impregnated with an acrylic based, UV stabilised resin. The resin is water repellent and contains a fire retardant.

TP450 has a self-adhesive side to aid initial location and is easy to apply in any weather. Additionally, TP450 has both thermal and acoustic insulation properties.

## Colour

Anthracite

## Packaging

Supplied as pre-compressed rolls with a self-adhesive side to aid initial location.

## Dimensions

Reference no.	Tape width /joint depth (mm)	Tape thickness/ joint width (mm)	Roll length (m)	Metres/ carton (m)
395995	14	4 - 10	5.8	121.8
395994	15	5 - 15	4.5	90
395993	25	10 - 24	7	84
308649	40	13 - 40	5.2	36.4
308650	50	13 - 50	5.2	31.2

## Technical Information

Property	Test Method	Result
Material		Polyurethane cellular foam, impregnated with a modified flame retardant artificial resin
Building Classification	DIN 4102	Impregnated with a modified flame retardant artificial resin B1, self-extinguishing, P-NDS 04-229
Thermal Conductivity	DIN 52612	$\lambda_{10} < 0.055 \text{ W/m/K}$
Vapour Resistivity	DIN 52615	$\mu < 100$
Weathering Test	DIN 53387	The requirements of DIN standards are met
Weathertight Against Driving Rain	EN 86/DIN 52453	The requirements of the DIN standard are met up to the described joint sizes, giving a minimum of 450 Pa, independently supervised by MPA Hannover
Compatability with Conventional Construction Methods	DIN 52453	No signs of corrosion observed on iron, zinc, steel, galvanised steel, aluminium and copper. No adverse effects with concrete, aerated concrete, brick, some stones, PVC, Plexiglas or timber
Service Temperature		-30°C to +90°C
Storage		Store rolls horizontally between +1°C and +25°C in dry conditions and away from direct sunlight. Re-seal packaging between use to prevent expansion during storage.
Shelf Life		2 years when stored in its original unopened containers.

## Tape Specification

- The tape should be selected so that the roll width (joint depth) is at least equal to the tape thickness in service (joint width). For applications outside of this instruction, please consult our sales office.



## TP450

### Compriband Timber Max

#### Usage / Purpose

TP450 provides a weather tight seal against the most severe combinations of wind and rain, with particular suitability for sealing the head and cills of windows installed in timber frame construction and can accommodate up to 37 mm of differential movement within a max. 50 mm wide joint.

Extensively tested, TP450 has a proven reputation across both the UK and Europe.

#### Key Benefits

- Minimum 450 Pa weather resistance to DIN EN 1027
- Accommodates up to 37 mm of joint movement within a maximum 50 mm wide gap
- Weather seal for wind-driven rain but breathable for vapour diffusion
- Can accommodate differential movement on timber frame construction up to 5 storeys
- Seals effectively – no remedial visits or wet sealants
- Continually expands and contracts to accommodate movement whilst still sealing the joints
- Long life expectancy

**Application**

- Detailed application instructions are available from the illbruck website.
- Before installation, measure the width of the joint and ensure the total movement, after any settlement, is within the capacity of the selected tape size (Fig 1 & 2).
- Cut off the preliminary strip and the opening wedge at the start of the roll.
- If installing tape into a construction joint, it may be applied either horizontally or vertically (from bottom to top); however, when applying to a door or window frame the horizontal seals must be applied before the vertical ones (Fig 4). Tape must be applied with the adhesive side to the frame when working with fenestration but may be applied in any order when working with construction joints. In both cases, do not stretch the tape. When working in damp or cold conditions a wood wedge should be used to hold the tape in position until it is expanded (Fig 3). Ensure the tape is recessed by a minimum of 2 mm from the front of the joint.
- When calculating the length of tape to be fitted, add 10 mm/m to the actual joint length. Be sure to measure the opening and not the window.
- At the end of a roll, cut off the tape wedge finish. Repeat the process with a new roll, making a close compressed butt connection as shown in Fig 3.
- If the seal is to be weather tested using the CWCT hose test (TN41), we recommend that the tape should be allowed 7 - 10 days conditioning in the joint before testing and a minimum 25 mm wide tape should be used. Please refer to technical department for advice.
- If using TP601 Compriband e to seal the window jambs (in conjunction with TP450 Compriband Timber Max to head and cill), cut and apply the TP601 Compriband e to the full height dimension of the frame. Cut and apply the TP450 Timber Max to span the full opening width, thereby covering the cut ends of the TP601 Compriband e. Ensure that the front (external) edges of both products are positioned in the same plane to achieve a continuous seal.
- For applications where the TP450 will exceed 30 mm thickness in service, the face of the tape should be covered using a suitable cover trim to improve the aesthetics and provide UV protection to the exposed tape surface.

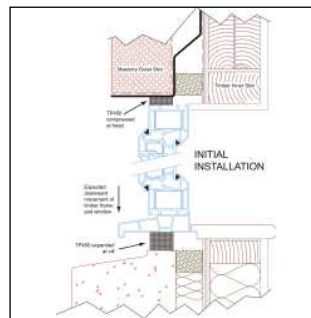

Fig 1 Location of TP450 Compriband Timber Max at initial installation

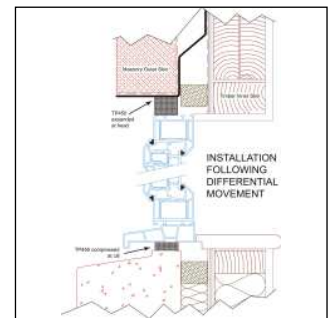

Fig 2 Expansion and compression of TP450 Compriband Timber Max after frame movement

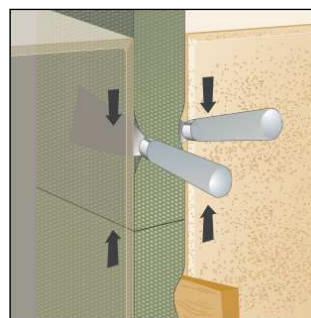

Fig 3 Compression of tape to make watertight butt joints

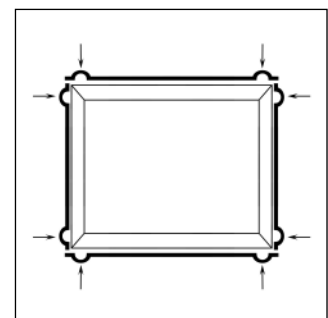

Fig 4 Tape application at corners (Note: oversize length 10 mm/m)

**Health & Safety Precautions**

Safety data sheet must be read and understood before use.

**Technical Service**

tremco illbruck has a team of experienced Technical Service Representatives who provide assistance in the selection and specification of products. For more detailed information, service and advice, please call Customer Service on 0191 419 0505.

**Guarantee / Warranty**

tremco illbruck products are manufactured to rigid standards of quality. Any product which has

been applied (a) in accordance with tremco illbruck written instructions and (b) in any application recommended by tremco illbruck, but which is proved to be defective, will be replaced free of charge. No liability can be accepted for the information provided in this leaflet although it is published in good faith and believed to be correct. tremco illbruck Ltd. reserves the right to alter product specifications without prior notice, in line with Company policy of continuous development and improvement.



**tremco illbruck Limited**  
 Coupland Road, Hindley Green  
 WN2 4HT Wigan  
 United Kingdom  
 T: +44 1942 251400  
 F: +44 1942 251410

info.uk@tremco-illbruck.com  
 www.tremco-illbruck.co.uk